

Council Liaison
Mark Gongora
Chairman
Chris Peltier
**Parks & Recreation
Director**
Megan Mainer



Commission Members
Bill Ahlstrom
Clara Dannhaus
Bonnie McDaniel
Jaime Moreno
Terry Roberts
Steven Sebok

**CITY OF ANGLETON, TEXAS
PUBLIC NOTICE OF A PARKS AND RECREATION BOARD MEETING
MONDAY, AUGUST 10, 2020, 5:30 P.M.
120 S. CHENANGO STREET ANGLETON, TEXAS 77515**

NOTICE IS HEREBY GIVEN PURSUANT TO V.T.C.A., GOVERNMENT CODE, CHAPTER 551, THAT THE PARKS AND RECREATION BOARD FOR THE CITY OF ANGLETON WILL CONDUCT A MEETING, OPEN TO THE PUBLIC, ON MONDAY, AUGUST, 2020, AT 5:30 A.M., AT THE CITY OF ANGLETON COUNCIL CHAMBERS LOCATED AT 120 S. CHENANGO STREET ANGLETON, TEXAS 77515.

In accordance with an Order of the Office of the Governor issued March 16, 2020, the Parks and Recreation Board Meeting of the City of Angleton, Texas will conduct the meeting scheduled at Monday, August 10, 2020, at 5:30 P.M., at The City of Angleton Council Chambers located at 120 S. Chenango Street Angleton, Texas 77515 and will be live-streamed on Facebook live at <https://www.facebook.com/cityofangleton/> to advance the public health goal of limiting face-to-face meetings (also called “social distancing”) to slow the spread of the Coronavirus (COVID-19). The City will follow the minimum recommended health protocols as set forth by the Texas Health and Human Services.

AGENDA

1. Declaration of a quorum and call to order.
2. Approve the minutes of Parks and Recreation Board meeting of June 15, 2020.
3. Discussion on Parks and Recreation Board meeting date and time.
4. Discussion on TMN agreement.

RECREATION

5. Discussion on Recreation Division updates.
 - a. Cost Recovery Policy Update
 - b. Capital Project Update
 - i. ADA Entry Doors
 - ii. Pool Exterior Doors

- iii. Pool Slide
- iv. RFP for Angleton Recreation Center Roof

PARKS

- 6. Discussion on Parks Division updates.
 - a. Welch Park Demolition
 - b. Municipal Pool Demolition
 - c. Disc Golf 18-Hole Course
 - d. Dog Park Entrance
- 7. Discussion on Lakeside Design Development.
- 8. Discussion on 75-acre park concept.
- 9. Discussion on Dickey Park Playground.
- 10. Discussion and possible action on Parkland Dedication Ordinance Draft.
- 11. Items for next meeting
- 12. Adjournment

CERTIFICATION

I, Megan Mainer, Parks and Recreation Director, do hereby certify that this Notice of a Parks and Recreation Board Meeting was posted on the City Hall bulletin board, a place convenient and readily accessible to the general public at all times and to the City’s website, www.angleton.tx.us, in compliance with Chapter 551, Texas Government Code. The said Notice was posted on the following date and time: Friday, August 7, 2020, by 5:30 a.m. and remained so posted continuously for at least 72 hours proceeding the scheduled time of said meeting.

/s/ Megan Mainer

Megan Mainer
Executive Director

In compliance with the Americans with Disabilities Act, the City of Angleton will provide reasonable accommodations for persons attending City meetings. The facility is wheelchair accessible and accessible parking spaces are available. To better serve you, please send your requests in advance. Please contact the City Secretary at 979-849-4364, extension 2115 or email faguilar@angleton.tx.us.



**CITY OF ANGLETON, TEXAS
AGENDA ITEM SUMMARY FORM**

MEETING DATE: 8/10/2020

ITEM #2

PREPARED BY: Megan Mainer

AGENDA ITEM TITLE: Discussion and possible action to approve the minutes of the Angleton Parks & Recreation Board regular called meeting of June 15, 2020.

AGENDA ITEM SECTION: (choose one below)

Ceremonial Presentation

Consent Agenda

Regular Agenda

Public Hearing

Executive Session

BUDGETED AMOUNT:

N/A

FUNDS REQUESTED:

N/A

FUND:

N/A

EXECUTIVE SUMMARY:

Regular called meeting of June 22, 2020 and Special called meeting of July 21, 2020.

ATTACHMENTS (Attachment description):

20200615Minutes_Final and 20200721 Minutes - Special Meeting

RECOMMENDATION:

Staff recommends Parks and Recreation Board approve the minutes.



**CITY OF ANGLETON
PUBLIC NOTICE OF A PARKS AND RECREATION BOARD MEETING
MONDAY, JUNE 15, 2020, 5:30 P.M.
120 S. CHENANGO STREET ANGLETON, TEXAS 77515**

THE FOLLOWING REPRESENTS THE ACTIONS TAKEN BY THE PARKS AND RECREATION BOARD IN THE ORDER THEY OCCURRED DURING THE MEETING. THE PARKS AND RECREATION BOARD, CONVENED IN A REGULAR MEETING ON MONDAY, JUNE 15, 2020, AT 5:30 P.M. IN THE ANGLETON CITY HALL COUNCIL CHAMBERS, 120 S. CHENANGO, ANGLETON, TEXAS.

1. Declaration of a quorum and call to order
With a quorum present, Parks and Recreation Chair Chris Peltier called the Parks and Recreation Board Meeting to order at 5:33 P.M. Council liaison Mark Gongora, Chairman Chris Peltier and Members Bill Ahlstrom, Clara Dannhaus, Bonnie McDaniel, Terry Roberts, Steven Sebok and Travis Townsend were present.

2. Approve the minutes of Parks and Recreation Board meeting of April 6, 2020 and May 12, 2020.
Upon a motion by Board Member McDaniel and seconded by Board Member Ahlstrom, the Parks and Recreation Board approved the minutes of the Parks and Recreation Board regular called meeting of April 6, 2020. The motion passed on a 6-0 vote. Member Sebok was off the dias.

3. Presentation on the Parkland Dedication ordinance.
No action taken.

4. Discussion regarding Parkland Dedication ordinance revisions
No action taken.

5. Discussion and possible action regarding an AGSA all night tournament at Bates Park July 3-4, 2020.
Upon a motion by Board Member Townsend and seconded by Board Member Peltier, the Parks and Recreation Board approved the AGSA all night tournament at Bates Park July 3-4, 2020. The motion passed on a 6-0 vote. Member Sebok was off the dias.

6. Discussion and possible action regarding the Cost Recovery Policy.

Upon a motion by Board Member McDaniel and seconded by Board Member Dannhaus, the Parks and Recreation Board approved the Cost Recovery Policy. The motion passed on a 6-0 vote. Member Sebok was off the dias.

7. Discussion and possible action regarding the Scholarship Policy.
Upon a motion by Board Member Townsend and seconded by Board Member Ahlstrom, the Parks and Recreation Board approved the Scholarship Policy. The motion passed on a 6-0 vote. Member Sebok was off the dias.
8. Discussion and possible action regarding the Park Memorial Policy.
No action was taken.
9. Discussion and possible action relocating Officer Cash Memorial Dog Park to Kiber and developing a new dog park design and elements.
Upon a motion by Board Member McDaniel and seconded by Board Member Roberts, the Parks and Recreation Board approved relocating Officer Cash Memorial Dog Park to Kiber and developing a new dog park design and elements. The motion passed on a 6-0 vote. Member Sebok was off the dias.
10. Discussion and possible action regarding demolishing obsolete park elements at Welch Park.
Upon a motion by Board Member McDaniel and seconded by Board Member Roberts, the Parks and Recreation Board approved demolishing obsolete park elements at Welch Park. The motion passed on a 6-0 vote. Member Sebok was off the dias.
11. Discussion and possible action regarding demolishing park elements at the Municipal Pool.
Upon a motion by Board Member Peltier and seconded by Board Member McDaniel, the Parks and Recreation Board approved demolishing park elements at the Municipal Pool and developing a new park design. The motion passed on a 6-0 vote. Member Sebok was off the dias.
12. Discussion and possible action regarding Dickey playground replacement and relocation.
Upon a motion by Board Member Roberts and seconded by Board Member Peltier, the Parks and Recreation Board approved Dickey playground replacement and relocation. The motion passed on a 6-0 vote. Member Sebok was off the dias.
13. Discussion and possible action regarding FY20-21 Budget.
Upon a motion by Board Member Peltier and seconded by Board Member McDaniel, the Parks and Recreation Board approved proposed FY20-21 Budget. The motion passed on a 6-0 vote. Member Sebok was off the dias.
14. Discussion regarding Lakeside Park design development timeline.
No action was taken.

- 15. Discussion regarding Freedom Park Master Plan and bridge.
No action was taken.
- 16. Discussion regarding hail damage to outdoor pavilions including Bates basketball pavilion.
No action was taken.
- 17. Discussion regarding Parks Board duties.
No action was taken.
- 18. Items for next meeting
Park Memorial policy, municipal pool shade structure relocation, and land acquisition opportunities.
- 19. Adjournment
Chris Peltier adjourned the meeting at 10:03 P.M.

These minutes were approved by Parks and Recreation Board on this the 13th day of July 2020 upon a motion by Parks Board Member, seconded by Parks Board Member. The motion passed on a 6-0 vote.

CITY OF ANGLETON, TEXAS

Chris Peltier
Chairman

ATTEST:

Megan Mainer, CPRP
Parks & Recreation Director



**CITY OF ANGLETON, TEXAS
AGENDA ITEM SUMMARY FORM**

MEETING DATE: 8/10/2020

ITEM #3

PREPARED BY: Megan Mainer

AGENDA ITEM TITLE: Discussion regarding Parks and Recreation meeting dates and time.

AGENDA ITEM SECTION: (choose one below)

Ceremonial Presentation

Consent Agenda

Regular Agenda

Public Hearing

Executive Session

BUDGETED AMOUNT:

N/A

FUNDS REQUESTED:

N/A

FUND:

N/A

EXECUTIVE SUMMARY:

Staff would like to determine if evenings are the best time to meet for Park and Recreation Board, or if meetings during the work hours are feasible. Additionally, staff would like to discuss the best day of the week to hold Park and Recreation Board.

ATTACHMENTS (Attachment description):

[Click here to enter text.](#)

RECOMMENDATION:

[Click here to enter text.](#)



**CITY OF ANGLETON, TEXAS
AGENDA ITEM SUMMARY FORM**

MEETING DATE: 8/10/2020

ITEM #4

PREPARED BY: Megan Mainer

AGENDA ITEM TITLE: Discussion on TMN agreement.

AGENDA ITEM SECTION: (choose one below)

Ceremonial Presentation

Consent Agenda

Regular Agenda

Public Hearing

Executive Session

BUDGETED AMOUNT:

N/A

FUNDS REQUESTED:

N/A

FUND:

N/A

EXECUTIVE SUMMARY:

Staff has been working with the Cradle of Texas Master Naturalist group regarding a partnership agreement for volunteer services, facility utilization and park projects.

The City Attorney has given staff direction to have TMN volunteers complete a volunteer application for the City rather than entering into an agreement. If a park project is proposed, the City Attorney recommends the project be vetted through the Parks and Recreation Board and City Council for approval before the organization proceeds.

ATTACHMENTS (Attachment description):

[Click here to enter text.](#)

RECOMMENDATION:

[Click here to enter text.](#)



**CITY OF ANGLETON, TEXAS
AGENDA ITEM SUMMARY FORM**

MEETING DATE: 8/10/2020

ITEM # 5

PREPARED BY: Megan Mainer

AGENDA ITEM TITLE: Discussion on Recreation Division updates.

AGENDA ITEM SECTION: (choose one below)

Ceremonial Presentation

Consent Agenda

Regular Agenda

Public Hearing

Executive Session

BUDGETED AMOUNT:

N/A

FUNDS REQUESTED:

N/A

FUND:

N/A

EXECUTIVE SUMMARY:

Staff brought the proposed Cost Recovery Policy to City Council on July 27. City Council requested additional information regarding resident and non-resident zip codes as it related to memberships and program usage. City Council, also, requested senior trips be brought down to a level four on the cost recovery model and that direct cost for senior trips not be an expectation. Staff will bring information requested, along with a new model and recommendation, to City Council on August 11 for consideration and adopting.

Several capital projects were removed from the Recreation Division budget for next fiscal year because there is a Recreation Fund Balance that can be used to address the following items: Automatic ADA entry doors, pool exit doors, flat roof and slide structure repairs. Staff is working towards developing RFPs for bids over \$50,000 and is also working on acquiring all quotes needed to proceed with repair and maintenance projects.

ATTACHMENTS (Attachment description):

Click here to enter text.

RECOMMENDATION: Click here to enter text.



**CITY OF ANGLETON, TEXAS
AGENDA ITEM SUMMARY FORM**

MEETING DATE: 8/10/2020

ITEM # 6

PREPARED BY: Megan Mainer

AGENDA ITEM TITLE: Discussion on Parks Division updates.

AGENDA ITEM SECTION: (choose one below)

Ceremonial Presentation

Consent Agenda

Regular Agenda

Public Hearing

Executive Session

BUDGETED AMOUNT:

N/A

FUNDS REQUESTED:

N/A

FUND:

N/A

EXECUTIVE SUMMARY:

Staff has asbestos testing done at Welch Park and the Municipal Pool. Both tests came back negative for asbestos. Public Works staff began demolishing Welch Park site amenities last week. We will continue cleanup on this site until it's complete.

Staff has solicited quotes for Municipal Pool demolition but has not received one to date.

On August 1, a volunteer group and parks staff installed new disc golf baskets at Dickey and Bates Park. Staff will plan a soft opening to solicit feedback from the disc golf community, make any changes that are needed and plan a grand opening following completion. Old baskets still need to be removed.

Staff has not addressed relocating Officer Cash Memorial Dog Park at this time.

ATTACHMENTS (Attachment description):

[Click here to enter text.](#)

RECOMMENDATION:[Click here to enter text.](#)



**CITY OF ANGLETON, TEXAS
AGENDA ITEM SUMMARY FORM**

MEETING DATE: 8/11/2020

ITEM #7

PREPARED BY: Megan Mainer

AGENDA ITEM TITLE: Discussion regarding Lakeside Park Design Development.

AGENDA ITEM SECTION: (choose one below)

Ceremonial Presentation

Consent Agenda

Regular Agenda

Public Hearing

Executive Session

BUDGETED AMOUNT:

N/A

FUNDS REQUESTED:

N/A

FUND:

N/A

EXECUTIVE SUMMARY:

On August 6, 2020, staff had a design development meeting with Clark Condon virtually to review changes to the site plan based on recommendations from the July 21 joint meeting with Parks and Recreation Board, ABLC, Lakeside Task Force and City Council. Clark Condon is still working on site adjustments, irrigation costs and landscaping to reduce costs. They've made changes to the pavilion that are attached for review and comments. Next joint meeting TBD but we are on schedule.

ATTACHMENTS (Attachment description):

RECOMMENDATION:

Click here to enter text.

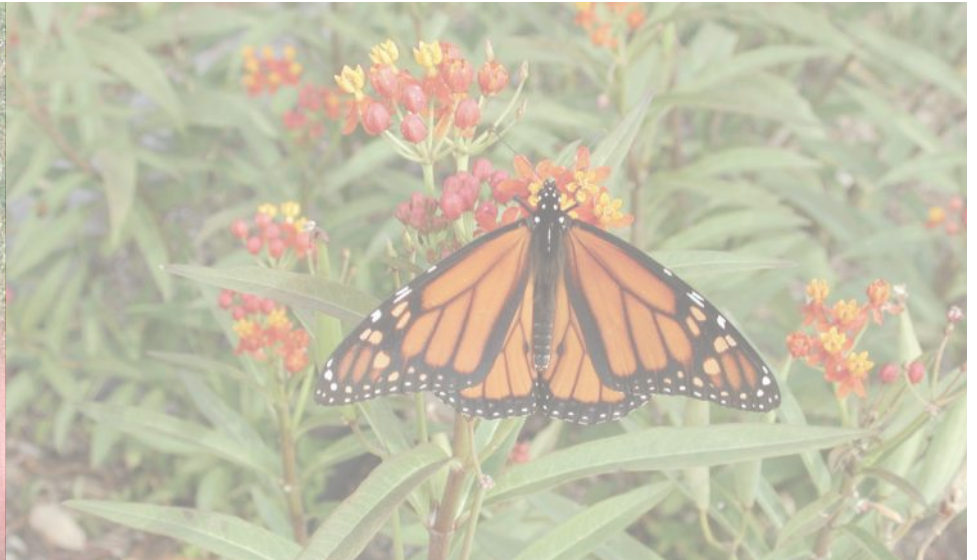

CITY OF ANGLETON

LAKESIDE PARK

08.06.2020

CCA PROJECT: 119-076



CLARK CONDON



PAVILION LAYOUT

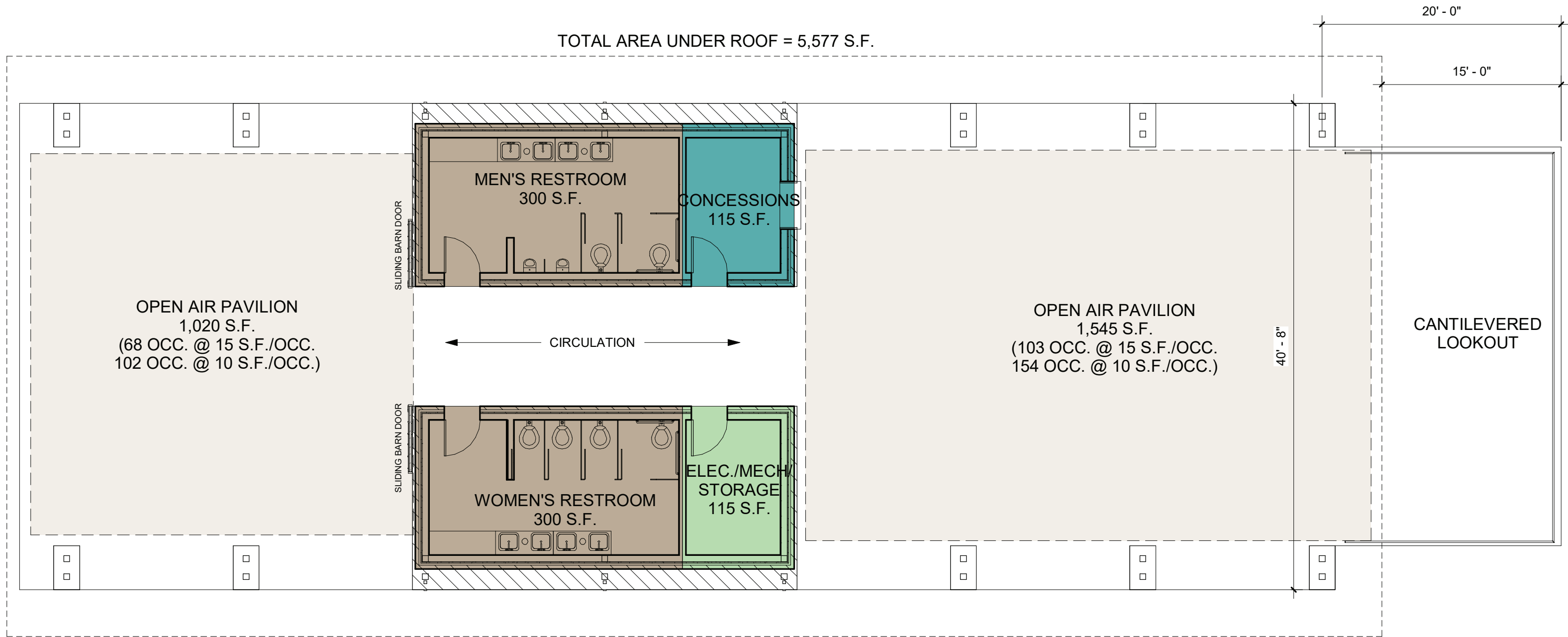

PAVILION: PERSPECTIVE VIEW



PAVILION: PERSPECTIVE VIEW



PAVILION: PERSPECTIVE VIEW



PAVILION: PERSPECTIVE VIEW



PAVILION: PERSPECTIVE VIEW



PAVILION: PERSPECTIVE VIEW



PAVILION: PERSPECTIVE VIEW



CLARK CONDON



**CITY OF ANGLETON, TEXAS
AGENDA ITEM SUMMARY FORM**

MEETING DATE: 8/11/2020

ITEM #8

PREPARED BY: Megan Mainer

AGENDA ITEM TITLE: Discussion on 75-acre park concept.

AGENDA ITEM SECTION: (choose one below)

Ceremonial Presentation

Consent Agenda

Regular Agenda

Public Hearing

Executive Session

BUDGETED AMOUNT:

N/A

FUNDS REQUESTED:

N/A

FUND:

N/A

EXECUTIVE SUMMARY:

Staff has begun researching ways to develop underutilized park space for public use. One consideration has been to develop an Off-Highway Vehicle Park on the 75-acres behind the wastewater treatment plant on Sebesta Road. Staff begin researching Texas courses and requirements provided by TPW. Staff found courses are typically 300 acres or more, charge a daily rate and some include campgrounds. Many are State Parks while others are private and municipally run. Costs for design have not been determined.

ATTACHMENTS (Attachment description):

OHV Park Research

RECOMMENDATION:

Click here to enter text.

OHV Park - 75 Acre Tract

Park Name	Location	Region	Size	Cost	Days of Operation	Features	Site offerings	Rules	Designed By/Contact	Frequent Visitors
Bamwell Mountain recreational area	Gilmer/Upshur County 6284 State Highway 155 North Gilmer, TX 75645	North Texas		Park Usage Fee Per Day - \$15.00/Family IRS dependants\$30.00/Each Park Guest Per Day; no vehicle free for members; \$5.00 non-members Primitive Camping Per Night - \$10.00 members; \$10.00 non-members Electric Camp Site Per Night (one vehicle and non-sharable) \$25.00 members; \$25.00 non-members Premium Camp Site Per Night (one vehicle and non-sharable) \$35.00 member;\$35.00 non-member Cabin 1 Per Night\$65.00 member; \$65.00 non-member Cabin 2 Per Night\$85.00member; \$85.00 non-member Cabin 3 Per Night\$75.00 member; \$75.00 non-member Cabins 4-6 Per Night\$95.00 member; \$95.00 non-member Bunkhouse Per Night\$50.00 member; \$50.00 non-member	Thursday 12PM - 10PM Friday 8AM - 12AM Saturday 8AM - 12AM Sunday 8AM - 6PM Monday 8AM-10PM Tuesday 8AM-10PM Wednesday 8AM-10PM Thursday 8AM-10PM Friday 8AM-10PM Saturday 8AM-10PM Sunday 8AM-10PM	ATVs, Motorcycles, ROVs & Full Size OHV's	Off roading and Camping			
Eisenhower State Park Northwest OHV Park	Denison/Lake Texoma/Grayson County 50 Park Road 20 Bridgeport/Wise County 2914 Hwy 101 Bridgeport, TX 76426	North Texas	300 acres	\$5.00 per person 12 and under - free Single vehicle (not to be driven off-road) \$4, resident discount \$2 ATV/Bike (vehicles with no roof or roll cage, must wear helmet) \$15; \$5 - resident discount SUV/Jeep \$25; \$10 - resident discount Camping (Available on Friday & Saturday Night) - Free	kids	ATVs and Motorcycles only				
Trophy Club Park at Grapevine Lake	Trophy Club/Denton County 100 Municipal Drive Trophy Club, TX 76262	North Texas		Entry Fee: \$15.00 per ATV paid at the park entrance OHV Decal: \$16.00	Monday8AM-8PM Tuesday8AM-8PM Wednesday8AM-8PM Thursday8AM-8PM Friday8AM-8PM Saturday8AM-8PM Sunday8AM-8PM	ATVs & Motorcycles only			Tony Jaramillo Director of Parks and Recreation tjaramillo@trophyclub.org Phone: 682-237-2923 Marvin Athans Parks Superintendent mathans@trophyclub.org Phone: 682-237-2925	
Xtreme Off Road Park and Beach	1927 Gulf Pump Rd, Crosby, TX 77532	South Texas	700 acres		Mon-TH 9AM-8PM & Sat 12PM-10PM MondayClosed	Fri ATVs, Motorcycles, ROVs & Full Size OHV's				
Mudbuddys Skeeter Motocross Park	5541 Co Rd 450, Hallettsville, TX 77964 5011 Hayes St, Alvin, TX 77511	South Texas South Texas	500 acres	\$20.00 1 bike 1 person per day per bike \$6.50 per person \$6.50 person without bike per day Children 6 & under are free unless they are riding a bike by themselves Children 7 & up is \$20 with/bike \$6.50 no bike tax is included on all bikes and people Free \$15	\$13.50 Tuesday9AM-7PM Wednesday9AM-7PM Thursday9AM-7PM Friday9AM-10PM Saturday9AM-10PM Sunday9AM-6PM	ATVs, Motorcycles, ROVs (trucks and jeeps are not allowed)				
Down South Offroad Park	807 Beaumont Hwy, Crosby, TX 77532	South Texas	700 acres		February Sat & Sun 9AM-6AM	ATVs, ROVs & Full Size OHV's (motorcycles and offroad bikes are not permitted)			Hunter (713) 633-7623	



**CITY OF ANGLETON, TEXAS
AGENDA ITEM SUMMARY FORM**

MEETING DATE: 8/11/2020

ITEM #9

PREPARED BY: Megan Mainer

AGENDA ITEM TITLE: Discussion on Dickey Park Playground.

AGENDA ITEM SECTION: (choose one below)

Ceremonial Presentation

Consent Agenda

Regular Agenda

Public Hearing

Executive Session

BUDGETED AMOUNT:

N/A

FUNDS REQUESTED:

N/A

FUND:

N/A

EXECUTIVE SUMMARY:

Staff has applied for a GameTime playground equipment grant. This grant only covers play structures and not supplemental materials or play elements like swing bays, concrete curbing, sidewalks, engineered wood fiber (EWF), and installation. The main structure is for ages 5-12 and the sub structure is for ages 2-5. During the City Council budget workshop, funding will be provided for Dickey Playground replacement since we will likely attain a playground grant. Staff is proposing the new play unit be located where the existing sand volleyball court is located. We plan to remove existing play structures that are located in different areas of the park and establish a new sand volleyball court near existing horseshoe pits.

ATTACHMENTS (Attachment description):

TJ-07088-20 Rev 1 Dickey Park - Concrete Curbs and Surfacing, TJ-07088-20 Rev 1 Dickey Park, TJ-07088-20-1A1R1, TJ-07088-20-2A1 and TJ-07088-20-2A2

RECOMMENDATION:

Staff recommends approval of the playground design as presented for City Council approval.



c/o Total Recreation Products, Inc.
 17802 Grant Road Cypress, Texas 77429
 Phone: 281-351-2402
 Toll Free: 800-392-9909
 Fax: 281-351-2493

08/07/2020
 Quote #100499-01-04

TJ-07088-20 Rev 1 Dickey Park

City of Angleton
 Attn: Megan Mainer
 1601 N Valderas St.
 Angleton, TX 77515
 Phone: 979-849-4364
 mmainer@angleton.tx.us

Ship to Zip 77301

Quantity	Part #	Description	Unit Price	Amount
1	RDU	GameTime - TJ-07088-20-2A1 PS20006 Nature Walk PowerScope 5-12 Play Unit	\$95,211.00	\$95,211.00
1	GRANT	GameTime - 2020 Grant Matching Funds	(\$39,204.56)	(\$39,204.56)
1	178749	GameTime - Owner's Kit	\$58.00	\$58.00
1	RDU	GameTime - TJ-07088-20-2A2 PT17008 Adirondack Trail 2-5 or 5-12 PrimeTime Play Unit	\$18,502.00	\$18,502.00
1	GRANT	GameTime - 2020 Grant Matching Funds	(\$7,618.48)	(\$7,618.48)
2	161290	GameTime - Geo-Textile 2250 Sqft Roll	\$681.00	\$1,362.00
1	3205	GameTime - Spinning Sensory Wave Seat	\$1,132.00	\$1,132.00
1	RDU	GameTime - 2 Bay PrimeTime Swing with (2) Belt Seats, (1) Expression Swing with Tot Seat and (1) Expression Swing with Adaptive Seat	\$5,796.00	\$5,796.00
1	INSTALL	GameTime - Installation of Above Equipment and Surfacing on quote 100499-01-03; - <i>No other site work, demolition or concrete work included. Acquisition of any and all permits is the sole responsibility of the customer.</i> <i>Standard installation does not include any extra or additional machinery, drillers, etc., for rock excavation. If rock conditions are encountered, additional charges will apply.</i>	\$33,177.57	\$33,177.57
Contract: Buy Board Contract #592-19			Sub Total	\$108,415.53
			Discount	(\$1,053.39)
			Estimated Freight	\$7,431.21
			Total	\$114,793.35

Comments

Freight Calculated to Installer's Zip Code 77301:

GRANT MATCHING FUNDS ARE AVAILABLE THROUGH November 15th, 2020 OR UNTIL EXHAUSTION OF FUNDS.

Funds match for Net 30 terms. You can receive \$10,033.46 in additional matching funds if you choose to make payment in full, by check or cash, at the time of your order.

Important Terms & Conditions - Please Review

To place an order, you must provide one of the following: a Purchase Order assigned to GameTime; or this Price Quotation, signed by an authorized purchaser, with a check made payable to GameTime. GameTime will also accept payment by Visa, MasterCard, or American Express. A current approved credit application is required for Net 30 terms.



c/o Total Recreation Products, Inc.
17802 Grant Road Cypress, Texas 77429
Phone: 281-351-2402
Toll Free: 800-392-9909
Fax: 281-351-2493

08/07/2020
Quote #100499-01-04

TJ-07088-20 Rev 1 Dickey Park

This quotation explicitly excludes any and all items not expressly specified or identified above. No other product, equipment, or service is included, regardless of any Contract Document, Contract Section, Plans, Specifications, Drawing, or Addendum. Delivery for most GameTime equipment is approximately 5-6 weeks after all order documents have been received and payment terms have been approved. A current, approved credit application is required for N30 terms. To place an order, you must provide a purchase order or a signed Total Recreation Products, Inc. (hereafter described as TRP) quote, assigned to GameTime. Neither general contractor nor subcontractor contracts can be accepted. Purchase documents that contain indemnity or hold harmless conditions cannot be accepted. Retainage is not permitted. The following must be received before your order can be processed: complete billing and shipping addresses, a contact name and phone #, and all color choices. Manufacturer's colors may vary from year to year. You are responsible for ensuring that any required submittal approvals are completed before placing your order for processing. TRP reserves the right to limit submittals to one copy. Shop drawings, blueines, sepias, are not available. Closeout documents may be limited to GameTime or TRP standard issue. If Sales Tax Exempt, a copy of your tax exemption form or resale certificate must accompany your order, or any applicable sales tax, will be added to your invoice. Most GameTime products are shipped from the Ft. Payne, AL plant. GameTime cannot hold orders or store equipment. Equipment is invoiced when shipped. If a cash sale, your payment must be received in full before the order will be processed. Contractors must also provide copies of current, fully executed bid/performance/payment bonds, as applicable. Pricing shown does not include any charges for permits, bonding, prevailing wage, or additional insured certifications.

Unless otherwise noted, any quantity of surfacing or playcurbs quoted has been calculated specifically for the equipment and layout shown. No additional surfacing or curbing is included, and no allowance has been made, for an unleveled, convoluted or larger site, or for a different layout. Neither GameTime nor TRP is responsible for any surface, curbing, border, or drain that is provided by others. Also please confirm that your area is adequate for the equipment that you are purchasing.

Installation charges, if quoted, are for a "standard" installation unless specifically noted to be otherwise. Installation charges are due upon completion. Standard installations are based upon a soil work site, that is freely accessible by truck, (no fencing, tree/landscaping or utility obstacles, etc.), and level, (+/- 1-2% maximum slope). An accessible water source must be available to the installer. Any site work that is not expressly described is excluded. Standard installation does not include any extra or additional machinery, drillers, etc., for rock excavation. If rock conditions are encountered, additional charges will apply.

Standard installations generally require from 2-10 business days to complete, depending upon the amount and type of equipment, site conditions, weather, and the installer's schedule. Work may or may not be performed in consecutive days. Playcurbs are staked in, not set in concrete. Engineered wood fiber and shredded rubber surfacings are spread, not compacted, rolled, or watered. Landscape timbers are not warranted. The Customer is responsible for locating and clearly marking all underground utilities in the installation area before any installation work can begin. The installer is not responsible for damages, repairs, or discontinuance of business due to damaged utilities.

If applicable, sprinkler system locates, re-working and repairs are excluded from installation charges. Installation of all products, (equipment, borders, fall surfacing and amenities) are as quoted and approved by acceptance of quotes and drawings. As a precautionary measure, work in progress areas will be taped off at the end of the workday. Pier spoils from installation shall be spread at site, site will be left rough grade. The installer is not responsible for any damages or re-work resulting from after hours events or activities during the work in progress period. Temporary fencing is only provided by specific request, and additional charges will apply. Collectively and/or individually, not the manufacturer, TRP, their representatives, nor the installation company shall be held liable for any damages resulting from misuse, vandalism, or neglect. Any deviations from approved and accepted placement of all items, along with additional work, over and above quoted items, will be chargeable to the customer. Once work is completed the customer will be notified if present at the job site, and all responsibility of any new work will be transferred to the customer. The customer is responsible for maintaining the integrity of completed installation work until all components have seated and/or cured (concrete footings, etc.). Your project site must be completely prepared and ready to receive your equipment before any installation work begins. Acquisition of any and all permits is the sole responsibility of the customer. Additional charges may be billed for any extra hours or trips needed as a result of the work site not being ready. Neither the installation contractor, GameTime nor TRP will be responsible for delays caused by shortages, incorrect parts, weather conditions, other contractors, or lack of site readiness.

If you are receiving your equipment, you are responsible for unloading and accepting delivery from the freight company and reporting any damaged freight or shortages on the freight bill at the time. You will also be responsible for a complete inventory of your received equipment and reporting any discrepancies to us immediately. Neither the freight company nor the manufacturer will resolve shipment discrepancies that are not reported immediately. Make sure that all items have been received before any type of installation work is scheduled. The freight carrier will be instructed to call your designated contact 24 hours before delivery to arrange a delivery appointment.

Once accepted, orders can only be changed or canceled with the consent of GameTime and TRP, and on terms that will indemnify them against loss. Changed or canceled orders are subject to a \$100.00 service charge. Additionally, canceled orders are subject to a 25% restocking fee, plus freight charges (to and from). Built-to-order equipment orders are non-cancelable. Changes to orders that have been shipped and invoiced are subject to the above \$100.00 service charge plus additional restocking/return charges of 25%. Non-returnable items shall be charged at full invoice value. Any return transportation charges shall be for the Buyer's account. Replacement parts are also subject to the cancellation/returns policy. Please carefully review any research information that has been sent to you and confirm that you are ordering the correct replacement parts for your equipment. This quotation is valid 30 days. After 30 days, please request an updated quote. Prices may be subject to material and fuel surcharges at the time of shipment and are subject to change without notice. Current prices will apply at the time of shipment. Acceptance of this quote indicates your agreement to GameTime's credit terms, which are net 30 days, FOB shipping with approved credit. Any deviations from this proposal may invalidate the quoted pricing and/or terms.



c/o Total Recreation Products, Inc.
17802 Grant Road Cypress, Texas 77429
Phone: 281-351-2402
Toll Free: 800-392-9909
Fax: 281-351-2493

08/07/2020
Quote #100499-01-04

TJ-07088-20 Rev 1 Dickey Park

THIS QUOTATION IS SUBJECT TO POLICES IN THE CURRENT GAMETIME PARK AND PLAYGROUND CATALOG AND THE FOLLOWING TERMS AND CONDITIONS. OUR QUOTATION IS BASED ON SHIPMENT OF ALL ITEMS AT ONE TIME TO A SINGLE DESTINATION, UNLESS NOTED, AND CHANGES ARE SUBJECT TO PRICE ADJUSTMENT. PURCHASES IN EXCESS OF \$1,000.00 TO BE SUPPORTED BY YOUR WRITTEN PURCHASE ORDER MADE OUT TO GAMETIME, C/O TOTAL RECREATION.

Please complete and return with your required form of payment:

Acceptance of quotation:

Accepted By (printed): _____

P.O. No: _____

Signature: _____

Date: _____

Title: _____

Phone: _____

Facsimilie: _____

Purchase Amount: \$114,793.35

Order Information:

Bill To: _____

Ship To: _____

Company: _____

Company: _____

Attn: _____

Attn: _____

Address: _____

Address: _____

City, State, Zip: _____

City, State, Zip: _____

Contact: _____

Contact: _____

Email Address: _____

Email Address: _____

Tel: _____

Tel: _____

Fax: _____

Fax: _____

For non-taxable purchases: Please also provide a copy of your Sales Tax Exemption Certificate or Resale Certificate.

Quote prepared by: Jennifer Roberts

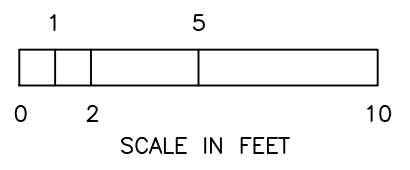
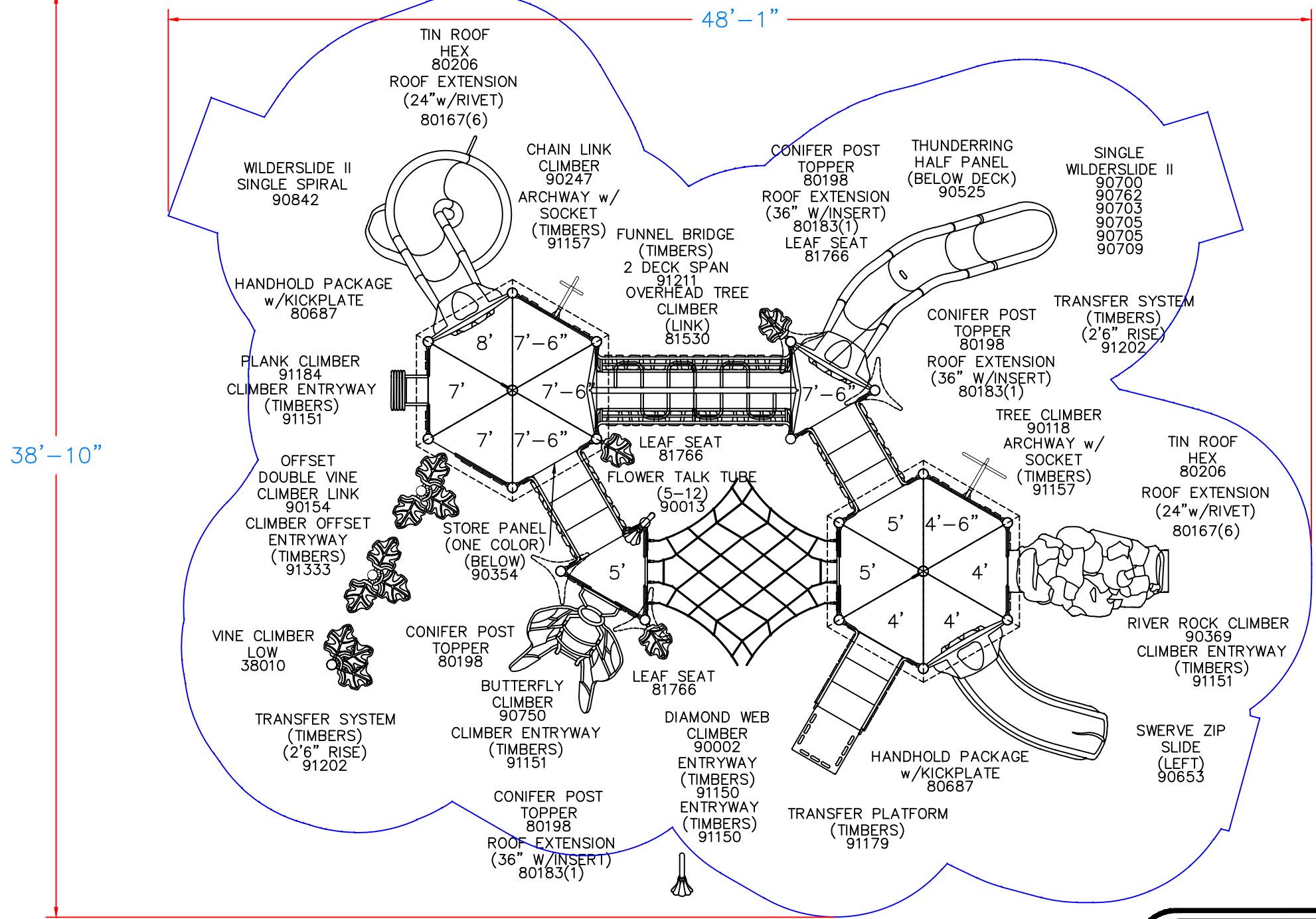

This Unit includes play events and routes or travel specifically designed for special needs users. It is the opinion of the manufacturer that these play events and routes of travel conform to the accessibility requirements of the ADA (Americans with Disabilities Act)

Total Elevated Play Components	11		
Total Elevated Play Components Accessible By Ramp	0	Required	0
Total Elevated Components Accessible By Transfer	11	Required	6
Total Accessible Ground Level Components Shown	8	Required	4
Total Different Types Of Ground Level Components	6	Required	3



City of Angleton - Dickey Park
 Naturewalk Unit
 Angleton, TX
 Representative
 Total Recreation Products, Inc

This play equipment is recommended for children ages
 5-12

Minimum Area Required:
 48'-1" X 38'-10"
 Scale:
 This drawing can be scaled only when in an 11" x 17" format

IMPORTANT: Soft resilient surfacing should be placed in the use zones of all equipment, as specified for each type of equipment, and at depths to meet the critical fall heights as specified by the U.S. consumer Product Safety Commission, ASTM standard F 1487 and Canadian Standard CAN/CSA-Z-614

Drawn By:
 JR
 Date:
 07/27/2020
 Drawing Name:
 TJ-07088-20-2A1

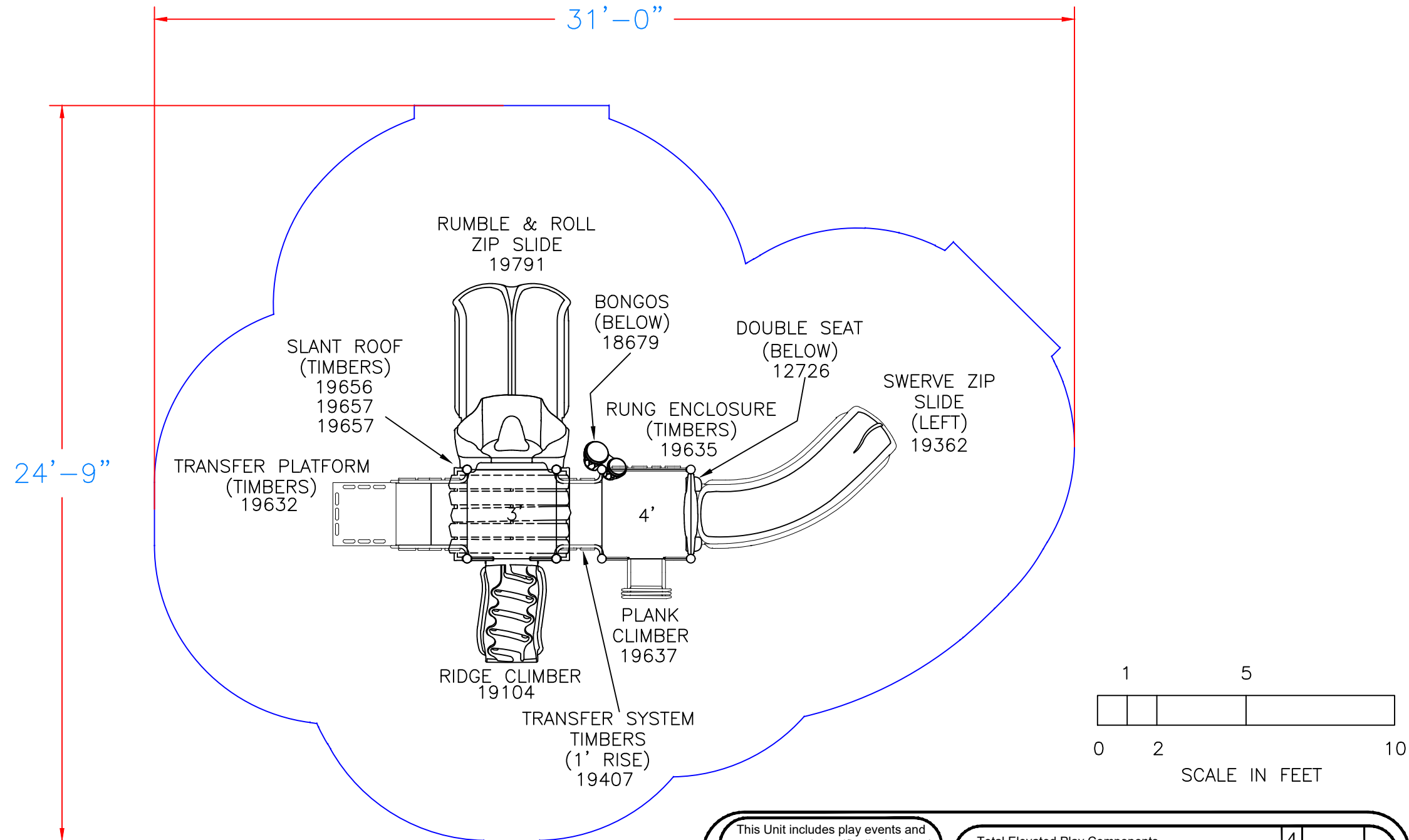

This Unit includes play events and routes or travel specifically designed for special needs users. It is the opinion of the manufacturer that these play events and routes of travel conform to the accessibility requirements of the ADA (Americans with Disabilities Act)

Total Elevated Play Components	4	Required	0
Total Elevated Play Components Accessible By Ramp	0	Required	0
Total Elevated Components Accessible By Transfer	4	Required	2
Total Accessible Ground Level Components Shown	2	Required	2
Total Different Types Of Ground Level Components	2	Required	2

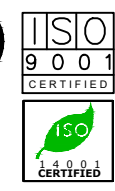

City of Angleton - Dickey Park
 PT17008 Adirondack Trail
 Angleton, TX
 Representative
 Total Recreation Products, Inc

This play equipment is recommended for children ages
 2-5 or 5-12

Minimum Area Required:
 31'-0" X 24'-9"
 Scale:
 This drawing can be scaled only when in an 8 1/2" x 11" format

IMPORTANT: Soft resilient surfacing should be placed in the use zones of all equipment, as specified for each type of equipment, and at depths to meet the critical fall heights as specified by the U.S. consumer Product Safety Commission, ASTM standard F 1487 and Canadian Standard CAN/CSA-Z-614

Drawn By:
 JR
 Date:
 08/05/2020
 Drawing Name:
 TJ-07088-20-2A2



c/o Total Recreation Products, Inc.
 17802 Grant Road Cypress, Texas 77429
 Phone: 281-351-2402
 Toll Free: 800-392-9909
 Fax: 281-351-2493

08/07/2020
 Quote #100499-01-03

TJ-07088-20 Rev 1 Dickey Park - Concrete Curbs and Surfacing

City of Angleton
 Attn: Megan Mainer
 1601 N Valderas St.
 Angleton, TX 77515
 Phone: 979-849-4364
 mmainer@angleton.tx.us

Ship to Zip 77301

Quantity	Part #	Description	Unit Price	Amount
1	INSTALL	GameTime - Installation of 295 LN FT of concrete curbs for Dickey Park as well as 17' x 5' Sidewalk, for quote 100499-01-04;- <i>No other site work, demolition or concrete work included. Acquisition of any and all permits is the sole responsibility of the customer.</i> <i>Standard installation does not include any extra or additional machinery, drillers, etc., for rock excavation. If rock conditions are encountered, additional charges will apply.</i>	\$12,964.29	\$12,964.29
1	W75465	GT-Impax - 212 Cubic Yards (4279 SF) of Engineered Wood Fiber Surfacing, Calculated at 12" Compacted Depth to Zip Code 77515- Price includes discount of \$833.83 and Freight	\$5,488.34	\$5,488.34
Contract: Buy Board Contract #592-19			Sub Total	\$18,452.63
			Total	\$18,452.63

Comments

Installation and Surfacing only;

Important Terms & Conditions - Please Review

To place an order, you must provide one of the following: a Purchase Order assigned to GameTime; or this Price Quotation, signed by an authorized purchaser, with a check made payable to GameTime. GameTime will also accept payment by Visa, MasterCard, or American Express. A current approved credit application is required for Net 30 terms.

This quotation explicitly excludes any and all items not expressly specified or identified above. No other product, equipment, or service is included, regardless of any Contract Document, Contract Section, Plans, Specifications, Drawing, or Addendum. Delivery for most GameTime equipment is approximately 5-6 weeks after all order documents have been received and payment terms have been approved. A current, approved credit application is required for N30 terms. To place an order, you must provide a purchase order or a signed Total Recreation Products, Inc. (hereafter described as TRP) quote, assigned to GameTime. Neither general contractor nor subcontractor contracts can be accepted. Purchase documents that contain indemnity or hold harmless conditions cannot be accepted. Retainage is not permitted. The following must be received before your order can be processed: complete billing and shipping addresses, a contact name and phone #, and all color choices. Manufacturer's colors may vary from year to year. You are responsible for ensuring that any required submittal approvals are completed before placing your order for processing. TRP reserves the right to limit submittals to one copy. Shop drawings, bluelines, sepias, are not available. Closeout documents may be limited to GameTime or TRP standard issue. If Sales Tax Exempt, a copy of your tax exemption form or resale certificate must accompany your order, or any applicable sales tax, will be added to your invoice. Most GameTime products are shipped from the Ft. Payne, AL plant. GameTime cannot hold orders or store equipment. **Equipment is invoiced when shipped.** If a cash sale, your payment must be received in full before the order will be processed. Contractors must also provide copies of current, fully executed bid/performance/payment bonds, as applicable. Pricing shown does not include any charges for permits, bonding, prevailing wage, or additional insured certifications.

Unless otherwise noted, any quantity of surfacing or playcurbs quoted has been calculated specifically for the equipment and layout shown. No additional surfacing or curbing is included, and no allowance has been made, for an unleveled, convoluted or larger site, or for a different layout. Neither GameTime nor TRP is responsible for any surface, curbing, border, or drain that is provided by others. Also please confirm that your area is adequate for the equipment that you are purchasing.



c/o Total Recreation Products, Inc.
 17802 Grant Road Cypress, Texas 77429
 Phone: 281-351-2402
 Toll Free: 800-392-9909
 Fax: 281-351-2493

08/07/2020
 Quote #100499-01-03

TJ-07088-20 Rev 1 Dickey Park - Concrete Curbs and Surfacing

Installation charges, if quoted, are for a "standard" installation unless specifically noted to be otherwise. Installation charges are due upon completion. Standard installations are based upon a soil work site, that is freely accessible by truck, (no fencing, tree/landscaping or utility obstacles, etc.), and level, (+/- 1-2% maximum slope). An accessible water source must be available to the installer. Any site work that is not expressly described is excluded. Standard installation does not include any extra or additional machinery, drillers, etc., for rock excavation. If rock conditions are encountered, additional charges will apply.

Standard installations generally require from 2-10 business days to complete, depending upon the amount and type of equipment, site conditions, weather, and the installer's schedule. Work may or may not be performed in consecutive days. Playcurbs are staked in, not set in concrete. Engineered wood fiber and shredded rubber surfacings are spread, not compacted, rolled, or watered. Landscape timbers are not warranted. The Customer is responsible for locating and clearly marking all underground utilities in the installation area before any installation work can begin. The installer is not responsible for damages, repairs, or discontinuance of business due to damaged utilities.

If applicable, sprinkler system locates, re-working and repairs are excluded from installation charges. Installation of all products, (equipment, borders, fall surfacing and amenities) are as quoted and approved by acceptance of quotes and drawings. As a precautionary measure, work in progress areas will be taped off at the end of the workday. Pier spoils from installation shall be spread at site, site will be left rough grade. The installer is not responsible for any damages or re-work resulting from after hours events or activities during the work in progress period. Temporary fencing is only provided by specific request, and additional charges will apply. Collectively and/or individually, not the manufacturer, TRP, their representatives, nor the installation company shall be held liable for any damages resulting from misuse, vandalism, or neglect. Any deviations from approved and accepted placement of all items, along with additional work, over and above quoted items, will be chargeable to the customer. Once work is completed the customer will be notified if present at the job site, and all responsibility of any new work will be transferred to the customer. The customer is responsible for maintaining the integrity of completed installation work until all components have seated and/or cured (concrete footings, etc.). Your project site must be completely prepared and ready to receive your equipment before any installation work begins. Acquisition of any and all permits is the sole responsibility of the customer. Additional charges may be billed for any extra hours or trips needed as a result of the work site not being ready. Neither the installation contractor, GameTime nor TRP will be responsible for delays caused by shortages, incorrect parts, weather conditions, other contractors, or lack of site readiness.

If you are receiving your equipment, you are responsible for unloading and accepting delivery from the freight company and reporting any damaged freight or shortages on the freight bill at the time. You will also be responsible for a complete inventory of your received equipment and reporting any discrepancies to us immediately. Neither the freight company nor the manufacturer will resolve shipment discrepancies that are not reported immediately. Make sure that all items have been received before any type of installation work is scheduled. The freight carrier will be instructed to call your designated contact 24 hours before delivery to arrange a delivery appointment.

Once accepted, orders can only be changed or canceled with the consent of GameTime and TRP, and on terms that will indemnify them against loss. Changed or canceled orders are subject to a \$100.00 service charge. Additionally, canceled orders are subject to a 25% restocking fee, plus freight charges (to and from). Built-to-order equipment orders are non-cancelable. Changes to orders that have been shipped and invoiced are subject to the above \$100.00 service charge plus additional restocking/return charges of 25%. Non-returnable items shall be charged at full invoice value. Any return transportation charges shall be for the Buyer's account. Replacement parts are also subject to the cancellation/returns policy. Please carefully review any research information that has been sent to you and confirm that you are ordering the correct replacement parts for your equipment. This quotation is valid 30 days. After 30 days, please request an updated quote. Prices may be subject to material and fuel surcharges at the time of shipment and are subject to change without notice. Current prices will apply at the time of shipment. Acceptance of this quote indicates your agreement to GameTime's credit terms, which are net 30 days, FOB shipping with approved credit. Any deviations from this proposal may invalidate the quoted pricing and/or terms.

THIS QUOTATION IS SUBJECT TO POLICES IN THE CURRENT GAMETIME PARK AND PLAYGROUND CATALOG AND THE FOLLOWING TERMS AND CONDITIONS. OUR QUOTATION IS BASED ON SHIPMENT OF ALL ITEMS AT ONE TIME TO A SINGLE DESTINATION, UNLESS NOTED, AND CHANGES ARE SUBJECT TO PRICE ADJUSTMENT. PURCHASES IN EXCESS OF \$1,000.00 TO BE SUPPORTED BY YOUR WRITTEN PURCHASE ORDER MADE OUT TO GAMETIME, C/O TOTAL RECREATION.

Please complete and return with your required form of payment:

Acceptance of quotation:

Accepted By (printed): _____

P.O. No: _____

Signature: _____

Date: _____

Title: _____

Phone: _____

Facsimilie: _____

Purchase Amount: \$18,452.63



c/o Total Recreation Products, Inc.
17802 Grant Road Cypress, Texas 77429
Phone: 281-351-2402
Toll Free: 800-392-9909
Fax: 281-351-2493

08/07/2020
Quote #100499-01-03

TJ-07088-20 Rev 1 Dickey Park - Concrete Curbs and Surfacing

Order Information:

Bill To: _____

Ship To: _____

Company: _____

Company: _____

Attn: _____

Attn: _____

Address: _____

Address: _____

City, State, Zip: _____

City, State, Zip: _____

Contact: _____

Contact: _____

Email Address: _____

Email Address: _____

Tel: _____

Tel: _____

Fax: _____

Fax: _____

For non-taxable purchases: Please also provide a copy of your Sales Tax Exemption Certificate or Resale Certificate.

Quote prepared by: Jennifer Roberts



Intellectual property of GameTime, a PlayCore Company. The site shown in rendering is an interpretation and may not reflect exact site conditions.

City of Angleton
Dickey Park
View 1



A PLAYCORE Company

www.gametime.com



www.totalrecreation.net



Intellectual property of GameTime, a PlayCore Company. The site shown in rendering is an interpretation and may not reflect exact site conditions.

City of Angleton
Dickey Park
View 2



www.gametime.com



www.totalrecreation.net



Intellectual property of GameTime, a PlayCore Company. The site shown in rendering is an interpretation and may not reflect exact site conditions.

City of Angleton
Dickey Park
View 3



www.gametime.com



www.totalrecreation.net



**CITY OF ANGLETON, TEXAS
AGENDA ITEM SUMMARY FORM**

MEETING DATE: 8/10/2020

ITEM #10

PREPARED BY: Megan Mainer

AGENDA ITEM TITLE: Discussion and possible action on Parkland Dedication Ordinance Draft.

AGENDA ITEM SECTION: (choose one below)

Ceremonial Presentation

Consent Agenda

Regular Agenda

Public Hearing

Executive Session

BUDGETED AMOUNT:

N/A

FUNDS REQUESTED:

N/A

FUND:

N/A

EXECUTIVE SUMMARY:

The City's Strategic Plan notes park development fees will be assessed. Overall, our current parkland dedication ordinance outlined in the LDC has errors and needs to be updated. Staff has hired Dr. Crompton from Texas A&M to revise the City of Angleton's Parkland Dedication ordinance. Based on comments received from the Parks and Recreation Board meeting on June 15, Dr. Crompton developed a revised Parkland Dedication Ordinance for Parks and Recreation Board consideration.

ATTACHMENTS (Attachment description):

AMENDMENTS TO THE CITY OF ANGLETON and Appendix A city of angleton

RECOMMENDATION:

Click here to enter text.

AMENDMENTS TO THE CITY OF ANGLETON'S PARK DEDICATION REQUIREMENTS; SEC. 23-20

A. Purpose.

It is hereby declared by the Angleton City Council that public park and recreation areas are valuable assets that advance the public's health, safety and welfare. This Section recognizes that park land dedication is a fair, reasonable and uniform method of financing these assets that does not impose an unfair burden on new or existing development. The intent is to require new development to pay its proportionate costs that are associated with providing new or expanded parks and conservation areas, so they are borne by the new homeowners who are responsible for creating the additional demand.

B. Applicability.

- (a) This Section applies to a landowner who develops land for residential use located within the City and its ETJ. Typically, the landowner of a proposed residential development is the developer.
- (b) Non-residential use is exempt.
- (c) This Section does not apply to activities involving the remodeling, rehabilitation or other improvements to an existing residential structure, or to the rebuilding of a damaged structure where no additional residential units are created.
- (d) If a dedication requirement was paid or encumbered prior to the amendment of this Section, then subsequent development for the subject tract to which the dedication requirement applies may be subject to vesting. However, if there is an increase in the number of dwelling units on the site, then there shall be a proportional increase in the dedication requirement.

C. General Requirements.

- (a) The City Manager or his/her designee shall administer this Chapter, with certain review, recommendation and approval authorities being assigned to the Planning Commission, the Recreation and Parks Commission, and various City departments as specified herein.
- (b) As a condition of subdivision development, a developer of residential property shall be required to dedicate land for parks; pay a fee in lieu thereof or a sanctioned alternative; or a combination of both. In addition to the land dedication, a developer of residential property shall pay a park development fee to be used to provide basic development a typically found in other Angleton city parks that is needed to make dedicated land into a functional park such as landscaping, tree planting, trails, restrooms, play equipment, car parking and pick-up basketball courts.

- (c) The required land dedications and schedules of fees are attached hereto as Appendix A. They are incorporated and made a part of this Section for all purposes.
- (d) The total amount of land dedicated for the development of a public park or conservation area shall be dedicated:
 - 1. In fee simple by filed deed;
 - 2. Prior to recordation of the final plat;
 - 3. For a phased development the entire park shall be platted concurrently with the plat of the first phase of the development.

D. Park Land Dedication Procedures

When considering park land dedication, the developer should meet with the Parks and Recreation Department (PARC) before a development application is submitted to evaluate the suitability of the land. Additionally, PARC may request a site visit as a part of its determination. The following information may be required as a part of the process, prior to accepting land as a public park dedication:

- 1. Lot dimensions or metes and bounds acreage of park land to be dedicated;
- 2. Total acreage of floodplain, as well as land located outside floodplain;
- 3. A tree survey;
- 4. A slope analysis; and
- 5. An environmental survey identifying critical environmental features, such as but not limited to species, habitat, and water features.

E. Park Land Acceptance Criteria.

(1) General Guidelines.

Any park land dedicated to the City pursuant to the terms, conditions and requirements under this Section must be suitable for park and recreation uses. The following guidelines should generally be met:

- (a) **Encumbrances.** Free and clear of any and all liens and encumbrances that interfere with use of the land for park purposes. The City's representatives must be permitted to make onsite inspections of the property for the purposes of determining site suitability and identification of any visual hazards or impediments to park development and use.
- (b) **Environmental Assessment.** If the property owner or developer has any form of environmental assessment on the tract, a copy of that assessment shall be provided to the City. The City may initiate and/or require the developer to initiate specific environmental studies or assessments if the visual inspection gives rise to the belief that an environmental problem may exist on the site. The Director of Parks and Recreation may require the employment of consultants necessary to evaluate any environmental issues relating to the site, providing that the City makes such determination in good faith. If an environmental hazard is identified, the developer must remove the hazard prior to its acceptance into the park and recreation system of the City. The City will not accept park land dedication sites encumbered by hazardous and/or waste materials or dump sites.
- (c) **Utilities.** The developer is responsible for certain minimum utilities as listed below. The Director of Parks and Recreation or his/her designee will be required to approve such location prior to final approval and release of fiscal requirements of said subdivision.

- i. A metered water supply located 12 feet behind the curb in accordance with the size of the park; and
 - ii. A six-inch sewer stub, or in accordance with the size of the park, ten feet behind the curb
- (d) If soils have been disturbed, they should be restored, and the soil stabilized by vegetative cover by the developer prior to dedication to the city.
- (e) Parks should be easy to access and open to public view to benefit area development, enhance the visual character of the City, protect public safety, and minimize conflict with adjacent land use.
- (f) Park and conservation land may provide a connection to existing or future City park land. The land available for dedication may be an opportunity to expand an existing or future city park or trail.
- (g) A current title report must be provided with the land dedication.
- (h) The property owner shall pay all taxes or assessments owed on the property up to the date of acceptance of the dedication by the City. A tax certificate from the County Tax Assessor shall be submitted with the dedication or plat.

(2). Land Requirements.

- (a) Land parcels that are unsuitable for development are typically unsuitable for parks. Hence, park sites should be selected prior to a subdivision being platted and acquired as a part of the development process.
- (b) Sites should be adjacent to residential areas in a manner that serves the greatest number of users and should be located to minimize users having to cross arterial roadways to access them.
- (c) Where feasible, sites should be located adjacent to schools to encourage shared facilities and joint development of new sites.
- (d) Parks should have well-drained and suitable soils and level topography. Sites should not be severely sloping or have unusual topography which would render the land unusable for recreational activities.
- (e) Park must be adjacent to a street for ease of pedestrian, bike or parking accommodations.
- (f) No more than two (2) sides of the park may be adjacent to the rears of homes.
- (g) Park must include visible, attractive and suitable means of ingress and egress proportionate to the size and amenities in the park.
- (h) The site should not be encumbered by overhead utility lines or easements which might limit the opportunity for park and conservation development.

- (i) Where appropriate, sites with existing trees or other scenic elements are preferred and may be reviewed by the City's Urban Forester to make recommendations.
- (j) Rare, unique, endangered, historic or other significant natural areas will be given a high priority for dedication pursuant to this Section.
- (k) Consideration will be given to land that is in the floodplain or may be considered "floodable" even though not in a federally regulated floodplain if it is suitable for park improvements. At the discretion of the City, land in floodplains may be considered as part of a dedication requirement on a three for one (3:1) basis. That is, three (3) acres of floodplain will be equal to one (1) acre of park land, but not more than 50% shall be allowed in a floodplain.
- (l) Detention/retention areas which are required as part of the stormwater management standards generally shall not qualify as parkland dedication, but may be accepted in addition to the required dedication. However, the City at its discretion may accept these areas on a three for one (3:1) basis if 75% or more of the active and useable area is designed for recreational use and the area conforms to the requirements below;
 - a. Detention areas shall not be inundated so as to be unusable for their designated recreational purposes. Detention areas must be designed to drain within 24 hours.
 - b. Detention areas shall be built of natural materials. Terracing, beaming and contouring is required in order to naturalize and enhance the aesthetics of the basin. Basin slopes shall not exceed a three to one (3:1) slope.
 - c. Detention areas may count a maximum of 50% of the park land dedication requirement.

F. Fee in Lieu of Park Land.

The City may, from time to time, require that a fee be submitted in lieu of land dedication in amounts as set forth in Appendix A for, either, both, some or park land dedications. Such fees shall be due at final platting.

The fee in lieu will be the average fair market value per acre of the land which is being subdivided at the time of the preliminary plat approval. The fair market value shall be established by the most recent appraisal of all or part of the property made by the appraisal district. At its discretion, the City may opt to commission an independent appraisal of the land by a third party and adjust the amount of assessed value based on any difference between it and the appraisal district's valuation.

G. Park Development Fee.

In addition to the park land dedication requirements, park development fees are established herein, sufficient to develop public parks in ways that meet the City of Angleton's standards. They are supplementary to, and not in substitution of, the land dedication requirement. The amount of development fees assessed to a development and the basis for the calculation is shown in Appendix A. The park development fees shall be processed simultaneously with the park land dedication requirements.

H. Public Park Improvement In Lieu of Park Development Fees

With the approval of the City, a developer may elect to construct required park improvements in lieu of paying the associated development fee as set forth herein. In such event:

- (a) Facilities and improvements provided by a developer shall be constructed on lands dedicated as public park land. All plans and specifications shall meet or exceed the City's standards at the time of the submission.
- (b) They shall be designed and installed to meet standards approved by the Director of Parks and Recreation, in accordance with related federal, national, state or local codes including, but not limited to, the following:
 - 1. International Play Equipment Manufacturer's Association (IPEMA);
 - 2. Consumer Product Safety Commission (CPSC) Handbook for Public Safety;
 - 3. American Society for Testing and Materials (ASTM and ASTM F08);
 - 4. Accessibility Standards for Play Areas through the ADA Accessibility Guidelines (ADAAG);
 - 5. Illuminating Engineering Society of North American (IESNA RP-6-01); and
 - 6. Sports Turf Management Association (STMA).

General Requirements for Public Park Improvements

- (a) A park site plan, developed in cooperation with the Parks and Recreation Department staff, is submitted. It is approved by the Director of the Parks and Recreation Department or his/her designee prior to submission of final plat.
- (b) Any public park land improvements must be shown on the site plan or construction plan, unless the Director of Parks and Recreation authorizes another method of approval. The improvements require review and approval of the City Engineer.
- (c) Detailed plans and specifications for park land improvements hereunder shall be due and processed in accordance with the procedures and requirements pertaining to public improvements for final plats.
- (d) All plans and specifications shall meet or exceed the City's standards in effect at the time of the submission.
- (e) If the improvements are constructed on land that has already been dedicated to and/or is owned by the City, then the developer must post payment and performance bonds equal to park development fees to guarantee the payment to subcontractors and suppliers and to guarantee the developer completes the work in accordance with the approved plans, specifications, ordinances, and other applicable laws. This includes guaranteeing performance in lieu of completing the park improvements prior to final plat recordation.
- (f) The developer shall be required to provide a two-year maintenance bond that is equal in amount to the twenty percent (20%) of the construction cost of said park improvements and a manufacturer's letter stating any play structure, equipment, and safety surfaces were installed in accordance with the manufacturer's installation requirement.
- (g) All manufacturers' warranties shall be provided for any equipment installed in the park as part of these improvements.
- (h) Upon issuance of a Certificate of Completion and Acceptance, the developer shall warrant the improvements for a period of two (2) years.
- (i) The developer shall be liable for any costs required to complete a park development if:

1. Developer fails to complete the improvements in accordance with the approved plans; or
 2. Developer fails to complete any warranty work.
- (j) All improvements shall be inspected by the City while construction is in progress, and when complete to verify requirements have been satisfied.
- (k) Once the improvements are constructed, and after the Director of Parks and Recreation has accepted such improvements, the developer shall convey such improvements to the city free and clear of any lien or other encumbrances.
- (l) The improvements will be considered complete with a Letter of Completion and Acceptance from the City and will be issued after the following requirements are met:
1. Improvements have been constructed in accordance with the approved plans;
 2. Improvements have been inspected and reviewed by PARD staff for satisfying park ordinance pursuant to the terms, conditions and requirements under this Section.

I. Credit for Private Park Amenities

- (a) Up to fifty percent (50%) of the total fee in lieu and park development fees required by this Section to be paid by a developer may be eligible for reimbursement if the developer provides private park amenities on the site. The remaining 50% is retained for deposit in the city's park land dedication fund for the purpose of defraying the financial burden that new residential units impose on the existing public park system in Angleton, beyond the immediate development in which their dwelling is located.
- (b) Private facilities eligible for credit are those outdoor amenities typically found in Angleton's public parks, which will substitute for the improvements otherwise funded by a dedication fee to meet the outdoor recreation needs of residents. These might include, but not be limited to, park land, playground equipment and shade structures, barbecue equipment, a "pick-up" basketball or volleyball court and lighting, and walking and jogging trails. Indoor recreation facilities provided by a developer do not qualify for credit.
- (c) The amount of credit shall be based on actual out-of-pocket dollar costs that the developer incurred in providing the outdoor recreation amenities:
- i. The developer is required to submit all invoices and checks paid toward the construction of the private amenities.
 - ii. The developer must allow PARD staff to conduct a site visit to verify the private park improvements.
- (d) Yards, court areas, setbacks and other open areas required to be maintained by the zoning and subdivision rules and regulation ordinances shall not be included in the credit computation.
- (e) Private ownership and maintenance of the private amenities shall be provided for in perpetuity by recorded agreement, covenants or restrictions that run with the land which cannot be eliminated without the consent of the City.

(f) Use of the private park is restricted for park and recreation purposes by recorded covenant, which runs with the land in favor of future owners of the property and which cannot be defeated or eliminated without the written consent of the City.

(g) Facilities must be similar or comparable to what would be required to meet public park standards and recreational needs as set forth in Section H and other federal, state and local laws.

(h) The design of private park amenities must be reviewed and approved by the Director of Parks and Recreation prior to the platting of the first unit.

(i) All private amenities should be constructed no later than prior to the application of the final unit building permit.

J. Reimbursement for City Acquired Park Land.

The City may from time to time acquire land for parks in advance of actual or potential development. If the City acts in this way, then the City may require subsequent dedications to be in fee in lieu of land only. They will serve to reimburse the City for the cost(s) of acquisition.

K. Appeal Process.

The property owner or applicant may appeal decisions relating to this Section to the Recreation and Park Board. The burden of proof is on the appellant to demonstrate that the decision was incorrect. The appellant must file a notice of appeal with the Director within thirty (30) days following the determination by the Director. Filing an appeal shall not stay collection of the fee due.

L. Use of Park Fees.

(a) Funds shall not be used for the operation and maintenance of parks.

(b) The park land dedication fund may not be used for city staff overhead expenses. Indirect costs reasonably incurred in connection with park land acquisition and development are limited to a maximum of 10 percent of total acquisition or development costs.

(c) All park land dedication and park development fees will be deposited in a separate fund. Funds shall be used solely for the acquisition or leasing of park land and the development, improvement, or enhancement of new and existing parks. All expenditures shall be administered in accordance with the current purchasing requirements of the City.

M. Review and Indexing of Fees

(a) The City shall review the fees established and the amount of park land dedication required in this Section at least once every five (5) years. Failure to review by the City Council shall not invalidate this ordinance.

(b) The fee-in-lieu and park improvement fees shall be automatically updated annually as part of the annual budgeting process unless otherwise authorized by the City Council. The update shall reflect the indexing shown in the U.S. Department of Labor Statistics Consumer Price Index for the Houston-The Woodlands-Sugar Land Statistical Area which includes Brazoria County.

N. Right to Refund.

The City shall account for all fees in lieu of land and all development fees paid under this Section with reference to the individual plat(s) involved. Any fees paid for such purposes must be expended by the City within ten (10) years from the date received by the City for acquisition and/or development of park areas as required herein. Such funds shall be considered to be spent on a first-in, first-out basis. If not so expended, the landowners of the property on the expiration of such period shall be entitled to a prorated share of such sum without interest, computed on a square footage of area basis. The owners of such property must request such refund within one (1) year of entitlement, in writing. Failure to timely submit the required application for refund shall constitute an absolute waiver of any right to the refund.

O. Severability.

If any provision of this Section is found to be unconstitutional or otherwise invalid by any court of competent jurisdiction, that invalidity shall not affect the remaining provisions of this Section, which can be implemented without the invalid provisions and, to this end, the provisions of this Section are declared to be severable. The City Council hereby declares that it would have adopted each and every provision and portion thereof not declared invalid or unconstitutional, without regard to whether any portion of the ordinance would subsequently be declared invalid or unconstitutional.

Appendix A.

Angleton Notional Parkland Dedication Calculation

Land Component.

Total city park acreage:	218.3 acres.
City Population:	19,875
Average occupancy per dwelling unit (Census data):	2.54
Number of dwelling units: (19,875/2.54)	7,825
Dwelling units per acre of parks: (7,825/218.3)	35.8

Assume market value of an acre of land for the new development is \$20,000.

Fee in lieu of dedication of land for each dwelling unit in the new development would be:

$$\$20,000/35.8: \underline{\$559}$$

Park Development Component.

Estimated cost of developing Lakewood Park:	\$5,000,000
Lakewood Park acres:	44.6 acres.
Park development cost per acre (\$5,000,000/44.6):	\$112,107
Dwelling units per acre of parks:	35.8
Fee per dwelling unit (112,107/35.8):	<u>\$3,131</u>

$$\text{Total Parkland Dedication Fee } (\$559 + 3,131) = \underline{\$3,690}$$